

**Nominal data**

| Type | 6318 /2 TDHP | |
|--------------------------|-------------------|----------|
| Nominal voltage | VDC | 48 |
| Nominal voltage range | VDC | 36 .. 72 |
| Speed (rpm) | min ⁻¹ | 5500 |
| Power consumption | W | 40 |
| Min. ambient temperature | °C | -20 |
| Max. ambient temperature | °C | 75 |
| Air flow | m ³ /h | 600 |
| Sound power level | B | 7.3 |
| Sound pressure level | dB(A) | 60 |

ml = Max. load · me = Max. efficiency · fa = Free air · cs = Customer specification · ce = Customer equipment
Subject to change

Technical description

| | |
|--|---|
| General description | 3-phase fan drive with very smooth operation and high efficiency Housing with grounding lug for M4 x 8 screw (Torx) Power consumption when wide open; these values may be considerably higher at the operating point. |
| Weight | 0.910 kg |
| Dimensions | Ø 172 x 51 mm |
| Impeller material | Glass-fiber reinforced PA plastic |
| Housing material | Die-cast aluminum |
| Airflow direction | Exhaust over struts |
| Direction of rotation | Counterclockwise, viewed toward rotor |
| Storage | Ball bearing |
| Service life L10 at 40 °C | 75000 h |
| Service life L10 at maximum temperature | 30000 h |
| Cable | With leads AWG 18, 20 or AWG 22, TR 64, speed signal and control input AWG 22 |
| Motor protection | Protection against reverse polarity and blocked rotor. |

Product drawing

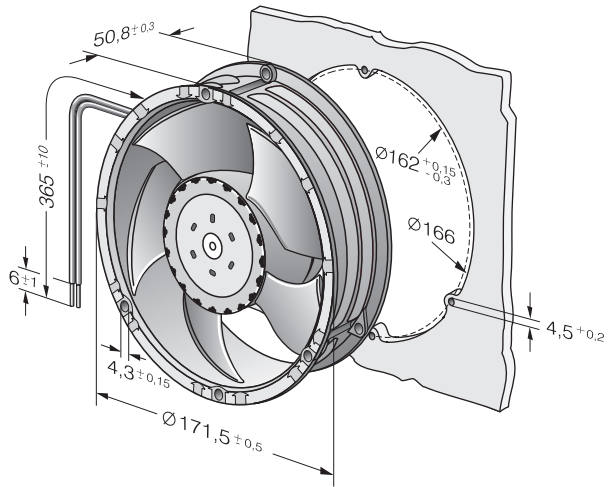

Curves

